



Specification Sheet

Part # HDL-8SV-XXW-XXK

Premium Designer 4' Linear Fixture

PROJECT NAME	
CATALOG #	
NOTES	
FIXTURE TYPE	

Product Description

How Digital's Premium Designer 4 foot Linear light fixture packages LEDs in a sleek, modern housing with aesthetic appeal and is offered with optional controls. Fixtures are also available with an optional EM battery that will provide illuminance for 90 minutes in event of a power outage. All How Digital LED fixtures are constructed with the latest generation of high efficacy LED chips, encased in a durable and rugged luminaire that will provide years of hassle-free use. 0-10V dimming and a 5 year product warranty are standard.

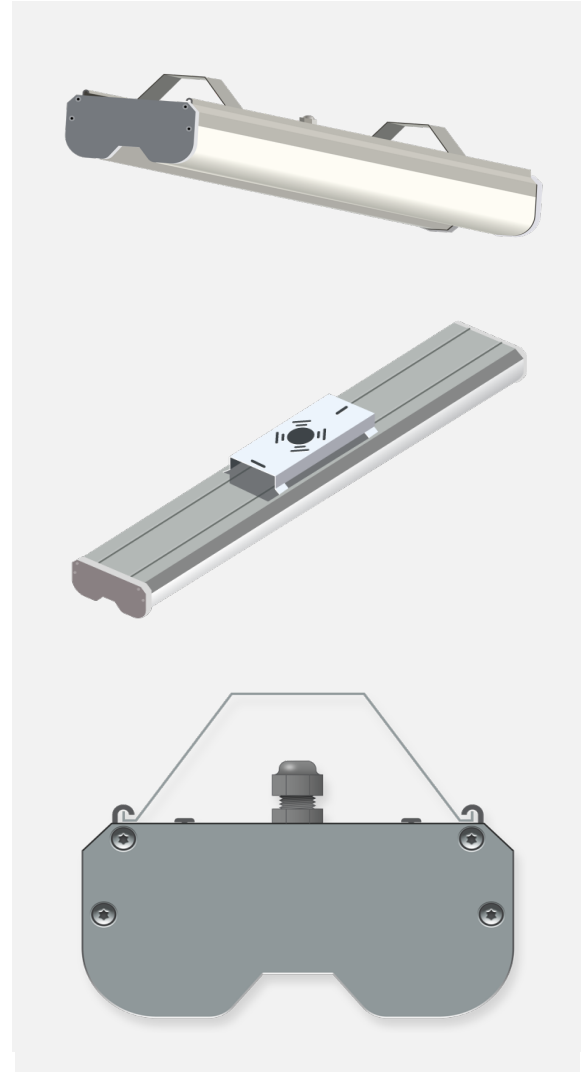

Part numbers and Specifications

Model	Watts	CCT	CRI	lm/W	Luminous Flux	Voltage	Size (in)
HDL-8SV-40W-XXK	40W	3000°k 3500°k 4000°k 5000°k	>80	>145	5,800 lm	100-277V	47 1/4" x 6 1/2" x 3 3/4"
HDL-8SV-75W-XXK	75W				10,875 lm		

Mounting Options: Surface or Pendant

Limited Warranty: 5 years

For additional warranty information visit www.howd.com

Spectra Ratio, Light Output and Distribution

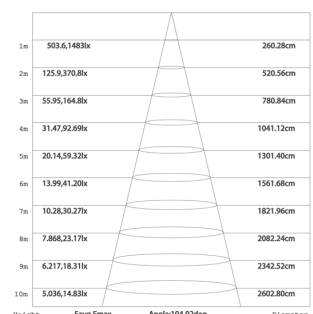
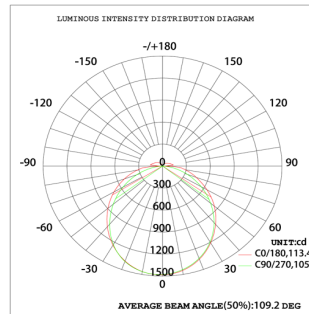
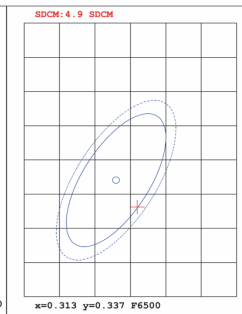
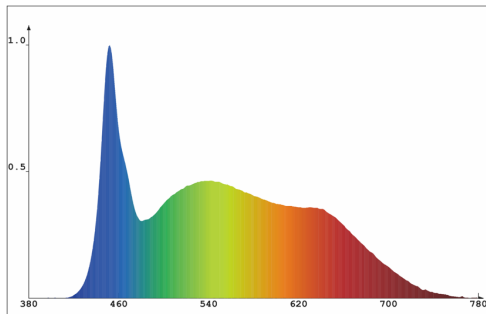

Part # HDL-8SV-XXW-XXK
Premium Designer 4' Linear Fixture

Applications

- Tunnels
- Garages
- Bridges
- Walkways
- Underpasses
- Stairwells
- Canopy Areas

Product Specifications

- 145 Lumens per Watt
- Impact Resistant Polycarbonate Lens
- Simple Installation
- Motion Sensor (optional)
- Enlighted Controller/Sensor (premium option)
- EM Battery (optional)
- Low Maintenance
- Operating Temperature: -40°F to 130°F
- >50,000 Lifetime Hours

Electrical System

- Input Voltage: 100-277V AC (50-60 Hz)
- Power Factor: >95%
- THD: ≤15% at Full Load
- Dimming: 0-10V
- Surge Protection: 5 kA

Test and Certifications

- ETL Listed
- IP65 Rated
- IES Files Available

Product Dimensions

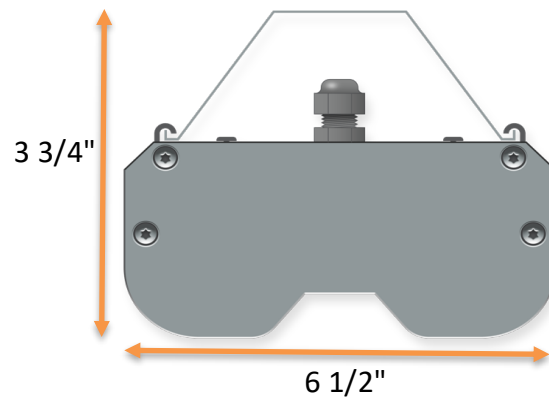

Length - 47 1/4"

